

11-16 FINAL DRIVE

Rear Axle

- Install the collar [A].
- Using a press and the bearing driver set, install the right side bearing [B] so that the bearing outside surface is flush [C] with the end face.

Special Tool - Bearing Driver Set: 57001-1129

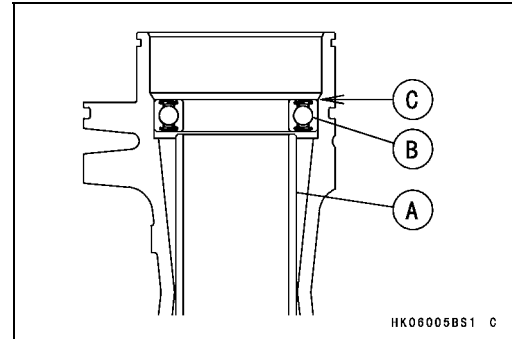

- Using a press and the bearing driver set, install the both side grease seals [A] so that the grease seal surface are flush [B] with the surface of the bearing housing.

Special Tool - Bearing Driver Set: 57001-1129

- Apply grease to the grease seal lips.

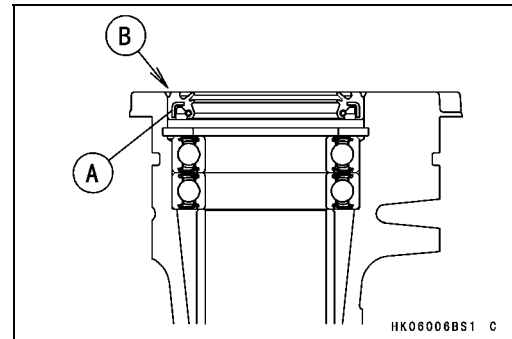

Rear Axle Bearing Housing Inspection

Since the bearings are made to extremely close tolerances, the clearance cannot normally be measured.

NOTE

○Do not remove any bearings for inspection. If any bearings are removed, they will need to be replaced with new ones.

- Turn each bearing in the housing back and forth [A] while checking for plays, roughness, or binding.
- ★ If bearing play, roughness, or binding is found, replace the bearing.
- Examine the bearing seal [B] for tears or leakage.
- ★ If the seal is torn or is leaking, replace the bearing.

