

Section 01 ENGINES (1503 4-TEC)

Subsection 03 (PTO HOUSING AND MAGNETO)

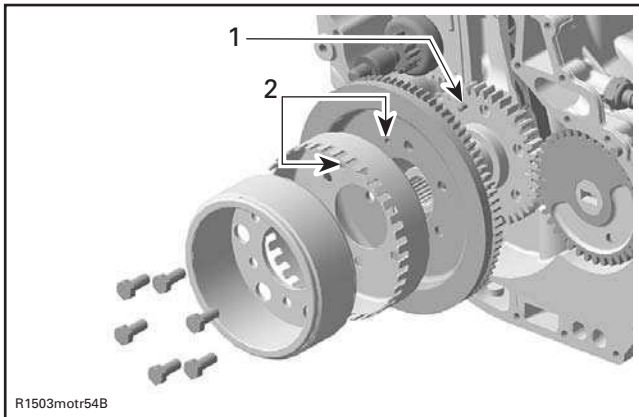

TYPICAL

1. Location pin
2. Location pin holes

Apply Loctite 243 (P/N 293 800 060) on threads.
Torque rotor screws to 24 N•m (17 lbf•ft).

STARTER DRIVE ASS'Y

Removal

Remove:

- PTO housing and ring gear as described above
- starter drive ass'y no. 8.

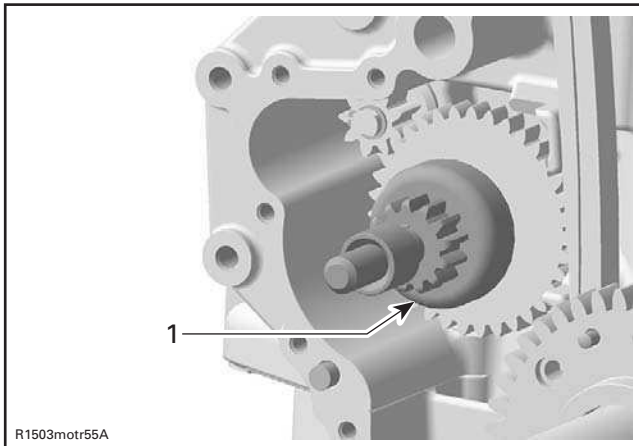

TYPICAL

1. Starter drive ass'y

CAUTION: Be careful not to lose the distance washer, disc springs no. 6 and washer no. 7 located on the starter drive shaft.

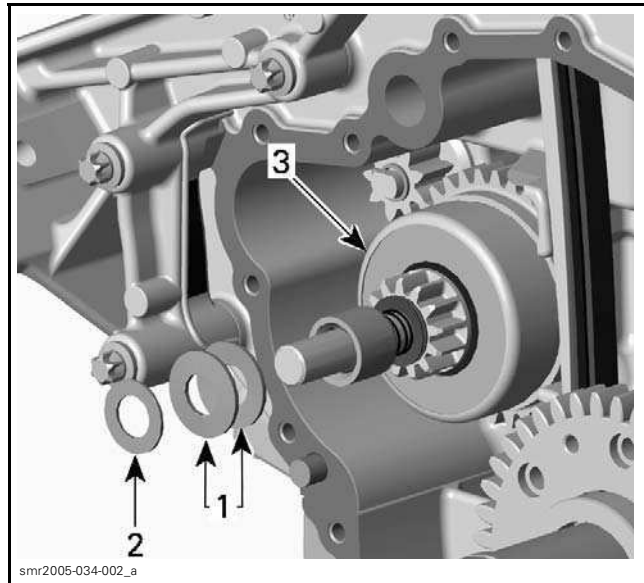

TYPICAL

1. Disc springs
2. Washer
3. Starter drive gear

Inspection

Check condition of the teeth, shaft, etc. and if the sprag clutch operates well. If damaged, replace faulty part.

Installation

For installation, reverse the removal procedure. However, pay attention to the following.

NOTE: When installing a new starter drive ass'y, oil the shaft and threads of the gear with engine oil.

Apply some Isoflex Topas NB52 grease (P/N 293 550 021) on the starter drive bearing located in the cylinder block and on the starter drive support in the PTO housing cover.